

Armatura da incasso CNC/INC 50

Lombardo.

LB1070039

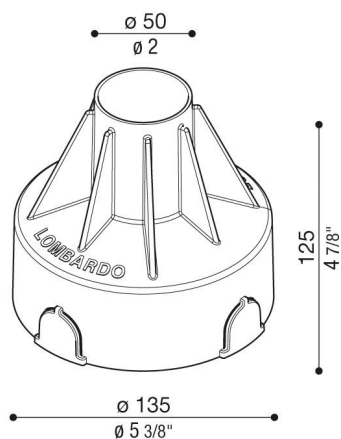

Generalità

Produttore:	Lombardo S.r.l.
Codice:	LB1070039
Pezzi per confezione:	1

Caratteristiche

Prodotti associati:	CNC 50 2.0 T, CNC 50 2.0 T Full Resin, Tegolo, Tegolo U&D, INC 50, CNC 50 Swing, CNC 50 T Up, CNC 50 T, CNC 50 Top L, CNC 50 Top 2L, CNC 50 Swing Spot
---------------------	--

Marchi di Conformità: 

Descrizione del prodotto:

Armatura da incasso in termoplastico.